

STANDBY
GENERATORS

GENERAC[®]
POWER SYSTEMS, INC.

PRODUCT CATALOG



RESIDENTIAL

COMMERCIAL

LIGHT
INDUSTRIAL

PORTABLE GENERATORS
AUTOMATIC STANDBY GENERATORS
TRANSFER SWITCHES AND ACCESSORIES



life is **better** with **power**



Better Power **More Choices**

We may not realize how much we depend on power in our daily lives. Heating, cooling, refrigeration, and lighting are necessities homes and businesses depend on. Job sites, campsites and special events use equipment requiring power where it may not be readily available. With extensive lines of both portable and automatic standby generators, Generac has comprehensive power solutions to cover any situation.

Automatic Standby Power **24/7 power protection from damaging power outages**

Unexpected power outages have become more frequent, with causes ranging from severe weather to an overtaxed power grid. With homes incorporating more electrical priorities, loss of power is a hassle easily solved with a flashlight and blanket. A power outage in winter can result in the loss of heat and burst pipes. In warm weather climates, a power outage can result in the loss of air conditioning and mold damage. In any climate, food left in refrigerators or freezers is likely to spoil. Businesses must shut down and consequently lose revenue.



These are significant issues for home and business owners with expensive consequences. Luckily, they can be avoided. With sizes ranging from 8 kW to 150 kW, Generac offers the broadest generator line in the industry. You can back up only the circuits you consider necessary or your entire home or business with 24/7 power protection. Protect the things that matter most to you with Generac – no other name in the industry compares.



Portable Power **Power to go wherever you need it**

The flexibility of portable power opens up unlimited possibilities. Always have a ready power supply for appliances on your camping trip, electric tools at the job site or unexpected home emergencies. Generac's general purpose GP and professional grade XP portable generator lines offer options for recreation, work or home. With sizes up to 17,500 Watts, you can take your power with you wherever you need it.



HOW MUCH POWER DO YOU NEED?



Whole-House Protection

Generac offers air-cooled and liquid-cooled generators that can supply up to whole-house protection. In conjunction with a transfer switch, this application completes your power solution package (see page 8 for options).

To accurately size liquid-cooled generators, a licensed electrician should apply an Amp meter to the circuits and appliances to determine the load requirement for back up.

Sizing Guide

Air Cooled Generator	8 kW	10 kW	14 kW	17 kW	Circuits	20 kW
5-Ton Central Air ¹			✓	✓	(50 Amp / 240V) ²	Whole-house Protection
4-Ton Central Air ¹			✓	✓	(40 Amp / 240V) ²	
3-Ton Central Air ¹	•	✓			(30 Amp / 240V) ²	
Well Pump or Water Heater		✓	✓	✓	(20 Amp / 240V) ²	
Family Room		✓		✓	(20 Amp / 120V)	
Master Bedroom	✓	✓	✓	✓	(20 Amp / 120V)	
Home Office			✓	✓	(20 Amp / 120V)	
Media Room		✓			(20 Amp / 120V)	
Garage			✓	✓	(20 Amp / 120V)	
Kitchen (#1) ³			✓	✓	(20 Amp / 120V)	
Kitchen (#2) ³	✓	✓	✓		(15 Amp / 120V)	
Bathroom	✓	✓	✓	✓	(15 Amp / 120V)	
Furnace	✓	✓	✓	✓	(15 Amp / 120V)	
Sump Pump	✓			✓	(15 Amp / 120V)	
Bedroom (#2)	✓		✓	✓	(15 Amp / 120V)	
Bedroom (#3)					(15 Amp / 120V)	
Bathroom (#2)				✓	(15 Amp / 120V)	

¹ Check your air conditioner's starting requirements. Starting requirements for older and/or less efficient equipment may exceed recommended generator capability. Additionally, for any electrical equipment or appliances, always check the manufacturer's power requirements. This will help to ensure standby power accommodations for items that cycle during operation.

² 240 volt appliances require 2 circuits ³ Most kitchens require multiple circuits

• For smaller central air up to 2 tons

Note: Rooms and appliances indicated here are for example only. You may choose others that better reflect your needs. Because of the cycling nature of some appliances such as refrigerators and furnaces, it may not be possible for all appliances to run simultaneously.

TRANSFER SWITCH CONFIGURATIONS

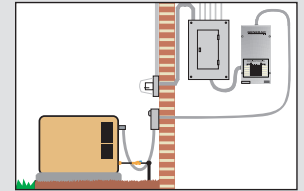

Automatic Transfer Switch Basic

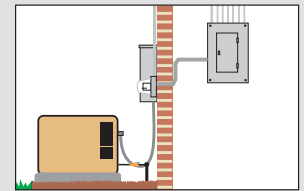

RTS-E models

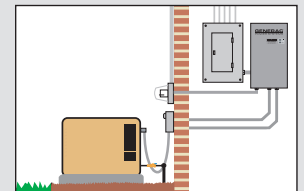

RTS-S models

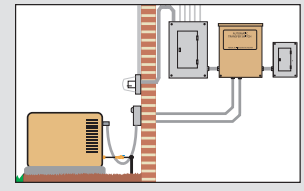

RTS-N models

Automatic Transfer Switch Basic is rated NEMA 1. All RTS-N, RTS-E & RTS-S transfer switches are NEMA 3R (outdoor/indoor) rated.

Note: Warranty coverage is not available for generators that are used for prime power (main power source) in place of the existing utility power where utility power is present or in place of utility power where utility power service does not normally exist. For life support or critical care applications, please see page 6 for industrial units.



Engine horsepower strength:

Generac OHVI® (Overhead Valve Industrial) engines are specifically designed for generator demands. The 2-year oil change interval, full-pressure lubrication system and spin-on oil filter contribute to the longest running engine in the industry.



Control Panel for 10 - 20 kW air-cooled generators

The easy-to-use control panel features user-friendly LCD digital controls, providing bilingual plain text display.

GENERAC AIR-COOLED MODELS

America's #1 selling home standby generator

Generac air-cooled models feature Generac's OHVI industrial engines for reliability and long life, and plateau honing to significantly decrease service intervals.



8-17 kW

8 KW / 10 KW / 14 KW / 17 KW MODELS (STEEL)

Air-cooled models for essential circuit protection

Smaller air-cooled models provide essential circuit protection for small to medium sized homes.

- **Continuous Fuel:** All models run on LP gas or natural gas, providing continuous power with reduced emissions.
- **Circuit Coverage:** Individual models can protect 8, 10, 12, 14, or 16 circuits in your home.
- **True Power™ Technology for sensitive electronics:** 10-17 kW units feature an electronic governor for smooth and consistent output with less than 5% total harmonic distortion for sensitive electronic equipment and appliances.
- **Steel Enclosures:** All steel enclosures feature durable galvanneal finish which bonds zinc to steel for superior rust and corrosion protection.
- **Composite Mounting Pad:** Provides for easier installation.
- **UL Listed:** UL 2200 Listing ensures the generator meets local building code approval, safety and certified kW power ratings.
- **External Dual GFCI Outlet:** Easy access to power for outdoor equipment available on 17 kW model.



17-20 kW

17 KW AND 20 KW MODELS (ALUMINUM)

The quietest and most powerful air-cooled protection on the market

These larger air-cooled models are the quietest and most powerful generators of their size on the market today. The 20 kW model includes the base fascia for a finished look and thorough protection. They include all the features of the 8-17 kW models above as well as the following:

- **Quiet-Test™:** The patented Quiet-Test low-speed exercise mode for up to 50% quieter weekly self-test.
- **Increased Circuit Coverage:** The 20 kW model provides up to whole-house protection.
- **Aluminum All-Weather Enclosures:** All-weather corrosion resistant aluminum enclosures prolong the life and look of the generator. Ideal for salt air coastal communities.
- **External Dual GFCI Outlet:** Easy access to power for outdoor equipment.



QUIET-TEST™

QT SERIES

The quiet standard in liquid-cooled automatic standby power

Generac's QT Series generators have redefined backup power for larger residential and commercial applications. These models feature automotive grade liquid-cooled engines for proven power and performance.

QUIET-TEST™

With outputs ranging from 22 to 150 kW, these QT models feature:

- **Quiet-Test™:** All models feature the patented Quiet-Test low-speed exercise mode for quieter weekly self-test.
- **Durable Enclosures:**
 - **Steel enclosures** have a galvanneal paint finish which bonds zinc to steel for superior rust and corrosion protection.
 - **Aluminum enclosures** are corrosion resistant and ideal for salt air coastal conditions.
- **Continuous Fuel:** All models run on LP gas or natural gas, providing continuous fuel and reduced emissions.
- **Stable Output:** Clean, consistent power for sensitive electronics. UL Listed.
- **Transfer Switches:** Matching transfer switches sold separately. Rated from 100 to 800 Amps. See page 8.

QUIET-TEST™

Quiet-Test™ feature:

Reduces noise by lowering engine speed during the generator's weekly self-test cycle. The ultra-quiet sound level is comparable to a car at idle, up to 50% quieter than when the generator is operating under normal load.

R-Series Controller for 22-60 kW Liquid-cooled generators

Full system monitoring including LED indicators for safety shutdowns, fuel pressure and battery voltage. Integrated transfer switch controller for RTS transfer switch.



H-100 Controller for 70 kW and above Liquid-cooled generators:

Offers quick access and simultaneous monitoring of key generator functions. Integrated transfer switch controller for HTS transfer switch.



22-60 kW

22 KW – 60 KW MODELS

Ideal for many large residential and commercial applications. A perfect size for small office buildings, churches, municipal buildings, retail centers, police stations, schools, farms, convenience stores and restaurants.



70-150 kW

70 KW – 150 KW MODELS

For applications that require more sophisticated monitoring and diagnostic capabilities, these provide a superior solution. Possible applications range from supermarkets, pumping stations to strip malls and hotels.



ADVANTAGES OF GASEOUS FUEL

- ✓ Natural gas is delivered reliably and continuously underground.
- ✓ Spark-ignited engines start more easily than diesel engines in cold climates. Spark-ignited engines are also quieter in terms of noise, vibration and harshness.
- ✓ Natural gas demand drops significantly during a power outage, assuring more than adequate supply.
- ✓ Gaseous fueled engines emit fewer pollutants than other fuels and are more environmentally friendly.

GEMINI® TWIN PACK FOR HIGHEST POWER DENSITY

When space is at a premium and reliability is critical, no other manufacturer comes close to Generac's Gemini Twin Pack.

Part of the MPS family, these units feature two 500 kW generators inside a single, weather resistant and sound attenuated enclosure. The exclusive PowerManager™ control system allows for combining the output of large, single engine gensets with a significant improvement in reliability.

- Smaller footprint than many comparable single engine models
- Built-in redundancy for superior system reliability
- Scalable solution – up to seven Gemini gensets can be paralleled without additional switchgear for up to 7,000 kW in total output
- Fast production turn around – often within weeks
- Easily serviced with common parts



THE GENERAC INDUSTRIAL DEALER NETWORK

Installation, start-up and servicing of Modular Power Systems require specialized knowledge and expertise. Generac Industrial Dealers have factory-trained personnel to ensure that your customers get the best possible solution, fast delivery, professional installation and start-up.

If a customer needs a diesel-powered generator or a generator size that is beyond the scope of the QT Series line, a Generac Industrial Dealer can meet requirements up to 9,000 kW.

Generac Industrial Dealer certified service technicians are fully trained on all QT Series generators and can provide your customers with hassle-free maintenance and service agreements.

INDUSTRIAL POWER FROM GENERAC'S MODULAR POWER SYSTEMS

For applications requiring greater amounts of standby power, the MQT100 and MQT150 models are ideal. Available through your local Generac Industrial Dealer, the output of these gensets can be combined to form a Generac Modular Power System (MPS). MQT Series Modular Power Systems are building blocks that link together to combine the power output equal to one large single generator. With the ability to parallel up to ten 100 kW units or up to ten 150 kW units, these generators can satisfy higher end requirements ranging from 100 to 1500 kW.



Redundancy

Because each MQT generator within the system backs up the others, critical loads receive extra protection and building managers enjoy greater peace of mind.

Serviceability

MQT generators use modified high volume truck or industrial engines that can be serviced using readily available, cost-effective parts. Since each generator backs up the others, servicing can be accomplished without losing backup power to critical loads.

Scalability

A Generac Modular Power System can be expanded as facilities grow. There is no need to replace the system if future power requirements exceed projections and no need to over-spend on a larger system that might never be fully utilized.

Flexibility

MPS modules provide unmatched flexibility because they can be placed in any configuration — side by side, end to end, together or apart. They are light enough for most rooftop applications and the lower weight eliminates the need for heavy-duty cranes and material handlers during installation.

BI-FUEL™

Longest Run Times in the Industry

Generac Bi-Fuel generators start on diesel fuel and add natural gas as load is applied. During an outage, they typically operate on a mixture of up to 70% natural gas and 30% diesel fuel (contact factory for product specifications). If the natural gas supply is interrupted, the generator automatically switches to 100% diesel without any power drop during the transition.

Benefits of Bi-Fuel

- Dramatically increased run times
- Minimal on-site fuel storage
- Reduced fuel maintenance
- Reduced environmental risk
- Lower particulate and NOx emissions



Better power. More choices.

From home use to camping, construction or outdoor events, Generac portable generators provide dependable portable power. Power the fun stuff or cover an emergency. The wide range of sizes gives you flexibility to choose as much power as you need.

- **Generac OHVI® Engine***: Generac's original and proven Overhead Valve Industrial engines provide the longest running time in the industry.
- **Electric Start***: Includes starting battery.
- **Never-Flat Wheels**: Provide all-terrain portability.
- **Hour Meter***: Tracks usage and includes maintenance resets.
- **Steel Fuel Tank**: Includes incorporated fuel gauge.
- **Low-Tone Muffler**: Provides quiet operation.
- **Fold-Down Handles**: Provide easy portability.

* See specs for available models.

XP SERIES

XP SERIES: 8000 WATTS

The professional grade XP Series of portable generators has been engineered for high performance. Durable construction with oversized full wrap frame tubing and impact resistant corners minimizes damage from rough handling. These rugged units also include:

- **True Power™ Technology** for utility quality electrical output for sensitive electronics
- **Low-Oil Pressure Protection** to protect engine from damage
- **Covered Outlets** for more protection from the environment
- **Start/Stop Fuel Shut-off and Choke Controls** conveniently located on outlet panel
- **External Battery Charge Jack**
- **Circuit Breaker Outlet Protection** including dual breakers on 120/240V outlets
- **Cord Set** included 25'/30 Amp
- **Maintenance Kit** included

GP SERIES

GP SERIES: 1800 — 8000 WATTS

Easy to use in a variety of applications, our GP series of portable generators offers affordable reliability. Features include:

- **Hardened Steel Tube Cradle** for durability
- **Low-Oil Shutdown** shuts engine down when oil runs low and prevents serious damage
- **Circuit Breaker Protected Outlets** for circuit protection
- **Hour Meter** with maintenance resets (excludes GP1800 and GP3250)

ULTRA SOURCE

ULTRA SOURCE™: 15000 WATTS & 17500 WATTS

Two of the most powerful portable generators on the market offer exceptional value. Generac portable generators are ideal on the job site, as an emergency power source at home or for commercial applications.

- **16-Gallon Fuel Tank** provides extended run time
- **Idle Control** increases fuel efficiency
- **Circuit Breaker Protected Outlets** for circuit protection
- **Included Accessories**: Maintenance kit, heavy duty wheel kit and lifting eye

XP SERIES



GP SERIES



ULTRA SOURCE



17500 WATT MANUAL TRANSFER SWITCH CONFIGURATION

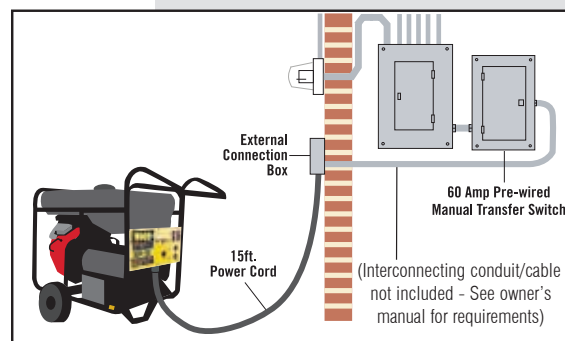

Included with the 17,500 Watt unit is a manual transfer switch with a built-in load center. Protecting up to 16 circuits, it provides enough power to start a variety of central air units. Includes 15'/50 Amp cord set.

POWERMASTER™ LOAD SHEDDING DEVICE

Create priority loads to ensure home comfort during a power loss! The PowerMaster is a load shedding device that allows a home owner to operate two large electrical loads instead of only one large appliance. Examples of this include a central air conditioner or an electrical hot water heater. When the priority load is running, the PowerMaster will lock out the other piece of equipment, keeping it from turning on until the demand is satisfied for the priority load. After the demand is satisfied, the PowerMaster allows the secondary load to come online and operate.



For use with units
up to 60 kW

TRANSFER SWITCHES

AUTOMATIC TRANSFER SWITCHES

As a part of the generator system, the transfer switch transfers the electrical load onto the generator when power fails. When utility voltage returns, the transfer switch safely returns circuit coverage back to the utility.

Distributed Load Center

Generac offers three models of automatic transfer switches for homeowners who choose to back up selected circuits rather than the entire house. Pre-wired load center models are available with a choice of 8, 10, 12, 14 or 16-circuits.

Generac makes installation easy and inexpensive.

All distributed load center models include:

- 30 ft. pre-wired conduit for connecting the transfer switch to the external connection box
- 2 ft. pre-wired conduit for moving circuits from the main panel to the transfer switch
- Pre-wired external connection box with a weather-proof conduit for generator connections



PowerManager™ Load Shedding Transfer Switch

The PowerManager LTS is designed to allow the most efficient use of the generator by monitoring and managing the backed up selected and non-selected circuits. If the generator approaches overload condition, the non-selected circuits are cycled off, allowing the selected circuits to remain powered. This switch is designed to operate with the digital controls that are used on air-cooled and liquid-cooled generators from 17 kW through 48 kW.

- Housed in an aluminum NEMA 3R, outdoor rated enclosure
- Service entrance rated at 200 Amps with built-in 16 circuit priority load center
- Main contactor protects the selected priority circuits while the secondary contactor protects the remaining, non-selected circuits located in the existing electrical panel
- Cover is side hinged for easy access



RTS Transfer Switches

RTS transfer switches are designed for a wide variety of applications that require up to 400 Amps. The RTS is integrated with the R-Series digital controller and operates only with standby generators thru 60 kW. NEMA 3R (outdoor rated) enclosures are standard.

RTS-N (Single-Phase)

Use RTS-N models for custom installations or with applications that require a sub-panel.

- 100, 200, or 400 Amp



RTS-E with Service Disconnect (Single-Phase)

Use RTS-E models with service disconnect for quick and easy installations. The transfer switch connects through the utility meter from outside.

- 100, 200, or 400 Amp
- Service-entrance rated and UL Listed (U.S. only)



(shown without cover)

THE GENREADY™ LOAD CENTER – The future in generator installation



The GenReady Load Center simplifies the generator system and installation and maximizes customer savings. In addition, advanced engineering creates the easiest and most cost-effective installation of any home standby generator on the market. New home construction, or renovations requiring electrical upgrades, are the opportune time to install a GenReady Load Center and a Generac automatic home standby generator.

With a traditional generator installation, three boxes are required: the main circuit panel, the automatic transfer switch, and the emergency circuit panel.

The GenReady Load Center replaces the main circuit panel and incorporates an automatic transfer switch so all power switching is handled within one unit. It becomes a hybrid panel capable of separating out only the electrical circuits the homeowner chooses to back up during a power outage.

Features include:

- 40 circuit capacity with the use of tandem breakers
- Dimensions same as a standard 42-circuit main load center
- Utilizes standard Siemens Load components
- Compatible with generators rated up to 125 Amps/30 kW



EZ TRANSFER OPERATOR™

The EZ Transfer Operator was developed by Generac to install into the GenReady Load Center. When installed with a generator, it automatically transfers the protected circuits from utility to generator power during a power outage. When utility is restored, the EZ Transfer Operator returns the circuits back to utility power.

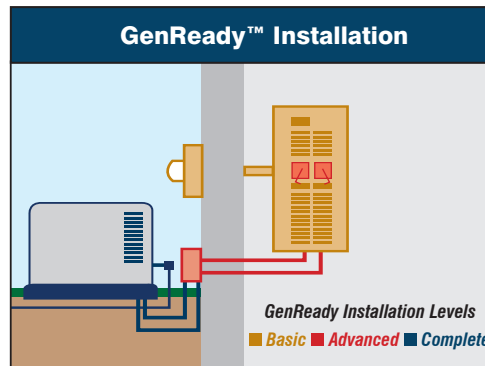
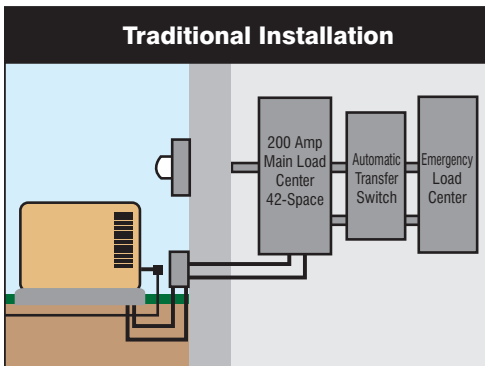
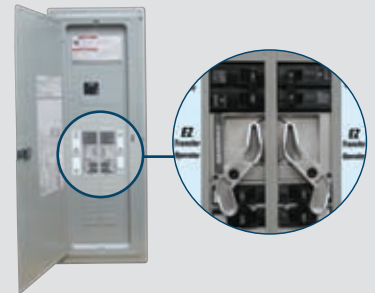

The innovative GenReady load center combines three boxes into one, saving space and money on generator installations!

HTS TRANSFER SWITCHES (Single-Phase and Three-Phase)

HTS transfer switches, designed for simple monitoring, operation and maintenance, are constructed to ensure superior performance. The HTS is part of an integrated system and operates only with Generac commercial-series generators (70-150 kW) with the H-100 controller. All switch components are front adjustable and removable for programming and servicing.



MODEL	RECOMMENDED SWITCH
QT022	RTS 100
QT025	RTS 100
QT027	RTS 100-200
QT030	RTS 100-200
QT035	RTS 100-200
QT045	RTS 100-200

MODEL	RECOMMENDED SWITCH
QT060	RTS 100-400
QT070	HTS 100-400
QT080	HTS 150-400
QT100	HTS 200-600
QT130	HTS 200-600
QT150	HTS 300-800



BUILDERS – Join the Generac Builder Alliance and get cash back for generator purchases

Offer your new home customers the safety and comfort of automatic standby power and increase your profits at the same time. Starting from the first unit you buy, Generac will give you cash back for your generator purchases. In addition to the profit earned from each sale, you will receive cash rebates for product purchased through your indicated Builder Alliance Partner(s).

Program Benefits:

As a builder, when you join the program you will receive:

- 200 New Home Owner brochures
- Marketing support cd
- Factory contact information and sales tools
- Information on installation training for your electrical contractor

Visit builder.generac.com to join.

Remote Wireless Monitor for Air-Cooled Generators

Add efficiency by allowing for remote viewing of generator status and parameters from inside the home.



Scheduled Maintenance Kits

A scheduled maintenance program will ensure that your system is always in top operating condition and that your warranty requirements are met. Generac offers a comprehensive line of scheduled maintenance kits to ensure long life and top performance of your generator system.

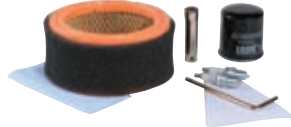

Cold Weather Kit

The cold weather kits are recommended for areas where the temperature drops below 30° F.



Fascia for Air-Cooled Units

Complement the contoured enclosure with a fascia base wrap that snaps together around the bottom of the generator. Fits air-cooled generators manufactured after April 2008 that have the contoured body wrap style. Fascia continues the sleek, contoured appearance as well as offering protection from rodents and insects by covering the lifting holes located in the base. Available in grey only. Standard on 20 kW air-cooled model.



Air-Cooled Generator Transport Cart

Moving a 400 lb generator can be hard work. The Generator Transport Cart will assist with moving the generator from the truck to the planned installation site. Allows for a single person to easily maneuver any air-cooled product to the desired installation location.



ACCESSORIES

Air-Cooled Remote Monitoring Options*	
Model	Description
5636	Remote wireless monitor
Liquid-Cooled Remote Monitoring Options 70 kW and above	
Model	Description
5464	Remote annunciator panel with 8 relays
5465	Remote annunciator panel without LEDs and keypad (relays only)
5466	Remote annunciator panel without relays
Air-Cooled Scheduled Maintenance Kit	
Model	Description
5661	7 kW, 410 cc kit
5662	8 kW, 410 cc kit
5663	10 kW, 530 cc kit
5664	12, 13, 14, 15, 16 kW, 17 & 18 kW, 760/990cc kit
5665	20 kW, 999 cc kit
Liquid-Cooled Scheduled Maintenance Kit	
Model	Description
5655	18 kW low speed aluminum, 20, 25 & 30 kW steel, 3600 RPM units, 1.6L units
5656	25 kW low speed aluminum & 45 kW steel, 3600 RPM units, 2.4L units
5657	60 kW unit, 3.0L units
5658	35 & 45 kW low speed, aluminum, 4.2L units
5659	80 kW, 4.6L kit units
5660	70, 100, 130, 150 kW, 6.8L units

Air-Cooled Cold Weather Kit			
Model	Description	Contents	
5634	For air-cooled units mfg prior to 4/08	Battery wrap with internal thermostat	
5635	For air-cooled units mfg after 4/08	Battery wrap with internal thermostat	
Liquid-Cooled Cold Weather Kit			
Model	Description	Contents	
5629	For 1.6L engines	28" Battery warmer w/oil filter	
5630	For 2.4L engines	28" Battery warmer, zip ties, thermostat	
5631	For 4.2L engines	44" Battery warmer, zip ties, thermostat	
5632	For 3.0, 4.6, 6.8 & 7.0L direct drive units	44" Battery warmer, zip ties, thermostat	
5633	For 6.8L gear drive units	44" Battery warmer, zip ties, thermostat & gear oil	
Liquid-Cooled Extreme Cold Weather Kit			
Model	Description	Contents	Use with cold weather kit #
5615	18 kW (3600 rpm), 20, 25, 30 kW (1.6L)	Block heater & mounting hardware	5629
5616	25 kW (1800 rpm), 45 kW (2.4L)	Block heater & mounting hardware	5630
5618	35 & 45 kW - both 1800 RPM (4.2L)	Block heater & mounting hardware	5631
5617	60 kW (3.0L)	Block heater & mounting hardware	5632
5619	80 kW (4.6L)	Block heater & mounting hardware	5633
5620	70, 100, 130 kW (6.8L)	Block heater & mounting hardware	5634
5667	150 kW (6.8L)	Block heater & mounting hardware	5635
Load Management Options			
Model	Description	Contents	Use with
5239	PowerMaster load shedding device	PowerMaster	60 kW & below
5621	Auxiliary transfer switch contact kit	Contact, screws & washers	R-style switch

Miscellaneous	
Model	Description
5651	Base plug for all liquid-cooled models
5652	Base plug for all air-cooled models mfg prior to 4/08
5654	Grey paint kit – Units mfg prior to 4/08
5653	Tan paint kit – Units mfg prior 4/08
5703	Bisque paint kit – Units mfg after 4/08
5704	Medium grey paint kit – Units mfg after 4/08
5685	Air-cooled generator transport cart
5666	Fascia for air-cooled units mfg after 4/08

* For use with 10-20 kW air-cooled generators manufactured after April 2008.

AIR-COOLED

Model	05526	05528	05530	05531	05532	05533
Rated Power (LPG/NG)	8/7 kW	10/9 kW	14/13 kW	17/16 kW	17/16 kW	20/18 kW
Voltage (Single-Phase)	120/240V	120/240V	120/240V	120/240V	120/240V	120/240V
Amps @ 120/240V LPG	66.6/33.3	83.3/41.6	116.6/58.3	141.6/70.8	141.6/70.8	166.6/83.3
Amps @ 120/240V NG	58.3/29.2	75/37.5	108.3/54.2	133.3/66.6	133.3/66.6	150/75
Engine/Alternator RPM	3600/3600	3600/3600	3600/3600	3600/3600	3600/3600	3600/3600
Engine	OHVI / 410cc	OHVI / 530cc	OHVI / 992cc	OHVI / 992cc	OHVI / 992cc	OHVI / 999cc
Fuel Consumption LPG	54 (1.47)	70 (1.93)	80 (2.18)	92 (2.51)	92 (2.51)	103.5 (2.85)
Fuel Consumption NG	119	156	220	245	245	262
Quiet-Test Low Speed Exercise	No	No	No	Yes	Yes	Yes
db(A) at Exercise	62	63	66	60	60	60
db(A) at Normal Operating Load	62	63	66	66	66	66
Enclosure	Steel	Steel	Steel	Steel	Aluminum	Aluminum
Enclosure Color	Bisque	Bisque	Bisque	Bisque	Gray	Gray
Dimensions (L" x W" x H")	48 x 24 x 28.25	48 x 24 x 28.25	48 x 24 x 28.25	48 x 24 x 28.25	48 x 24 x 28.25	48 x 24 x 28.25
Generator Weight (lbs.)	336	375	425.5	445	414	451

TRANSFER SWITCHES

Model	RTSD100A1	RTSF100A1	RTSH100A1	RTSP100A1	RTSW100A1	RTSS200A3 Load Shedding	5447 EZ Transfer Operator	5488 GenReady	5499 GenReady w/ EZ Transfer Operator	
Amp Rating	100	100	100	100	100	200	N/A	200/125	200/125	
Number of Circuits	8	10	12	14	16	16 Priority	N/A	40	40	
Breakers	1 x 30 Amp, 2 pole 1 x 20 Amp, 1 pole 5 x 15 Amp, 1 pole	1 x 30 Amp, 2 pole 1 x 20 Amp, 2 pole 3 x 20 Amp, 1 pole 3 x 15 Amp, 1 pole	1 x 40 Amp, 2 pole 1 x 30 Amp, 2 pole 3 x 20 Amp, 1 pole 5 x 15 Amp, 1 pole	1 x 50 Amp, 2 pole 1 x 40 Amp, 2 pole 1 x 20 Amp, 2 pole 4 x 20 Amp, 1 pole 4 x 15 Amp, 1 pole	1 x 50 Amp, 2 pole 1 x 40 Amp, 2 pole 1 x 20 Amp, 2 pole 5 x 20 Amp, 1 pole 5 x 15 Amp, 1 pole	1 x 50 Amp, 2 pole 1 x 40 Amp, 2 pole 1 x 20 Amp, 2 pole 5 x 20 Amp, 1 pole 5 x 15 Amp, 1 pole	1 x 50 Amp, 2 pole 1 x 40 Amp, 2 pole 1 x 20 Amp, 2 pole 5 x 20 Amp, 1 pole 5 x 15 Amp, 1 pole	N/A	N/A	N/A
Load Transition Type	Open	Open	Open	Open	Open	Open	Open	N/A	Open	
Voltage	120/240	120/240	120/240	120/240	120/240	120/240	N/A	120/240	120/240	
Phase	Single	Single	Single	Single	Single	Single	N/A	Single	Single	
Enclosure Type	NEMA 1	NEMA 1	NEMA 1	NEMA 1	NEMA 1	NEMA 1R, 3R	N/A	NEMA 1	NEMA 1	
Dimensions (H" x W" x D")	29.5 x 12.1 x 6.8	29.5 x 12.1 x 6.8	29.5 x 12.1 x 6.8	29.5 x 12.1 x 6.8	29.5 x 12.1 x 6.8	29.5 x 12.1 x 6.8	42.5 x 21 x 8.25	42 x 15 x 4	42 x 15 x 4	
Weight (lbs)	62	72	76	78	80	80	3.5	45.5	49	

Model	RTSN100A3	RTSE100A3	RTSN100G3	RTSN100K3	RTSN100J3	RTSN200A3	RTSE200A3	RTSN200G3	RTSN200J3	RTSN200K3	RTSN400A3	RTSE400A3	RTSN400G3	RTSN400J3	
Amp Rating	100	100	100	100	100	200	200	200	200	200	400	400	400	400	
Load Transition Type	Open	Open w/ Service Disconnect	Open	Open	Open	Open	Open w/ Service Disconnect	Open	Open	Open	Open	Open w/ Service Disconnect	Open	Open	
Voltage	120/240	120/240	120/208	277/480	120/240	120/240	120/240	120/208	120/240	277/480	120/240	120/240	120/208	120/240	
Phase	Single	Single	Three	Three	Three	Single	Single	Three	Three	Three	Single	Single	Three	Three	
Enclosure Type	NEMA 3R	NEMA 3R	NEMA 3R	NEMA 3R	NEMA 3R	NEMA 3R	NEMA 3R	NEMA 3R	NEMA 3R	NEMA 3R	NEMA 3R	NEMA 3R	NEMA 3R	NEMA 3R	
Dimensions (H" x W" x D")	20 x 15.2 x 7.3	20 x 15.2 x 7.3	24 x 20.5 x 7.3	36 x 24.5 x 10.2	24 x 20.5 x 7.3	20 x 15 x 7.3	30 x 16.5 x 7.3	24 x 20.5 x 7.3	24 x 20.5 x 7.3	24 x 20.5 x 7.3	48 x 30.6 x 13.3	36.1 x 24.4 x 10.2	40 x 31 x 10.5	36.1 x 24.4 x 10.2	36.1 x 24.4 x 10.2
Weight (lbs)	35	52	49	95	95	35	58	49	49	105	88	134	107	107	

Model	HTSN100A	HTSN100G	HTSN100J	HTSN100K	HTSN150A	HTSN150G	HTSN150K	HTSN200A	HTSN200G	HTSN200J	HTSN200K	HTSN300A	HTSN300G	HTSN300J	HTSN300K	
Amp Rating	100	100	100	100	150	150	150	200	200	200	200	300	300	300	300	
Load Transition Type	Open	Open	Open	Open	Open	Open	Open	Open	Open	Open	Open	Open	Open	Open	Open	
Voltage	120/240	120/208	120/240	277/480	120/240	120/208	277/480	120/240	120/208	120/240	277/480	120/240	120/208	120/240	277/480	
Phase	Single	Three	Three	Three	Single	Three	Three	Single	Three	Three	Three	Single	Three	Three	Three	
Enclosure Type	NEMA 1/3R	NEMA 1/3R	NEMA 1/3R	NEMA 1/3R	NEMA 1/3R	NEMA 1/3R	NEMA 1/3R	NEMA 1/3R	NEMA 1/3R	NEMA 1/3R	NEMA 1/3R	NEMA 1/3R	NEMA 1/3R	NEMA 1/3R	NEMA 1/3R	
Dimensions (H" x W" x D")	36 x 24 x 10	36 x 24 x 10	36 x 24 x 10	36 x 24 x 10	36 x 24 x 10	36 x 24 x 10	36 x 24 x 10	36 x 24 x 10	36 x 24 x 10	36 x 24 x 10	36 x 24 x 10	48 x 30 x 12	36 x 24 x 10	36 x 24 x 10	36 x 24 x 10	48 x 30 x 12
Weight (lbs)	86 / 112	86 / 112	86/112	105 / 131	86 / 112	89 / 115	105 / 131	86 / 112	89 / 115	89 / 115	105 / 131	101 / 127	108 / 134	108 / 134	124 / 150	

Model	HTSN400A	HTSN400G	HTSN400J	HTSN400K	HTSN600A	HTSN600G	HTSN600J	HTSN600K	HTSN800A	HTSN800G	HTSN800K
Amp Rating	400	400	400	400	600	600	600	600	800	800	800
Load Transition Type	Open Transition	Open Transition	Open Transition	Open Transition	Open Transition	Open Transition	Open Transition	Open Transition	Open Transition	Open Transition	Open Transition
Voltage	120/240	120/208	120/240	277/480	120/240	120/208	120/240	277/480	120/240	120/208	277/480
Phase	Single	Three	Three	Three	Single	Three	Three	Three	Single	Three	Three
Enclosure Type	NEMA 1/3R	NEMA 1/3R	NEMA 1/3R	NEMA 1/3R	NEMA 12/3R	NEMA 12/3R	NEMA 12/3R	NEMA 12/3R	NEMA 12/3R	NEMA 12/3R	NEMA 12/3R
Dimensions (H" x W" x D")	36 x 24 x 10	36 x 24 x 10	36 x 24 x 10	48 x 30 x 12	60 x 36 x 20	60 x 36 x 20	60 x 36 x 20	60 x 36 x 20	60 x 36 x 20	60 x 36 x 20	60 x 36 x 20
Weight (lbs)											
NEMA 1 / NEMA 3R	101 / 127	101 / 127	101 / 127	124 / 150	N/A	N/A	N/A	N/A	N/A	N/A	N/A
NEMA 12 / NEMA 3R	N/A	N/A	N/A	N/A	650 / 650	650 / 650	650/650	650 / 650	680 / 680	680 / 680	680 / 680

LIQUID-COOLED

Series	QT02224	QT02516	QT02524	QT02724	QT03016	QT03542	QT03624	QT04524*
Rated Power LP	22 kW	25 kW	25 kW	27 kW	30 kW	35 kW	36 kW	45 kW
Rated Power NG	22 kW	24 kW	24 kW	25 kW	29 kW	35 kW	35 kW	45 kW
Amps @ 240V, 1 Ø LP	91.6	104.2	104.2	112.5	120.8	146	150	187.5
Amps @ 208V, 3 Ø LP	76	86.8	86.8	94	104.2	121.5	125	156.3
Amps @ 240V, 3 Ø LP ¹	N/A	N/A	N/A	N/A	N/A	105.3	108	135.4
Amps @ 480V, 3 Ø LP	N/A	N/A	N/A	N/A	N/A	52.6	54	67.7
Engine/Alternator RPM	1800/1800	3600/3600	1800/1800	1800/1800	3600/3600	1800/1800	1800/1800	3600/3600
Engine Size	2.4L	1.6L	2.4L	2.4L	1.6L	4.2L	2.4L	2.4L
Cylinder Arrangement	In-line 4	In-line 4	In-line 4	In-line 4	In-line 4	V-6	In-line 4	In-line 4
Fuel Consumption LPG	120 (3.3)	175 (4.81)	142 (3.91)	149 (4.1)	209 (5.7)	185.5 (5.1)	199 (5.4)	286 (7.86)
Fuel Consumption NG	316	437	375	359	525	485	480	720
Quiet-Test Low Speed Mode	Yes	Yes	Yes	Yes	Yes	Yes	Yes	Yes
db(A) at Exercise	61	62	54	61	62	60	58	61
db(A) at Normal Operating Load	70	74	60	70	75	65	64	73
Transfer Switch Type Needed	RTS	RTS	RTS	RTS	RTS	RTS	RTS	RTS
Enclosure Material	Aluminum	Steel	Aluminum	Aluminum	Steel	Aluminum	Aluminum	Steel
Enclosure Color	Gray	Bisque	Gray	Gray	Bisque	Bisque	Bisque	Bisque
Dimensions (L" x W" x H")	62.2 x 29 x 33.5	62.2 x 29 x 33.5	62.2 x 29 x 33.5	62.2 x 29 x 33.5	62.2 x 29 x 33.5	77 x 33.5 x 45	77 x 33.5 x 45	77 x 33.5 x 45
Generator Weight Steel (lbs.)	N/A	875	N/A	N/A	935	N/A	N/A	1414/1464 ²
Generator Weight Aluminum (lbs.)	843	N/A	1276	891	N/A	1683	1683	N/A

* California emission compliant model. Must specify with "Y" at end of typecode when ordered.

1 Consult factory for availability

** Height does not include measurement of exhaust stack(s).

2 California emission compliant model weight

*** All specifications subject to change without notice.

PORTABLE

Series	GP1800	GP3250	GP5500	GP6500	GP7000	GP7000E
Model #	5723	5724	5736	5623	5625	5626
Running Watts	1800 Watts	3250 Watts	5500 Watts	6500 Watts	7000 Watts	7000 Watts
Starting Watts	2050 Watts	3750 Watts	6875 Watts	8000 Watts	8750 Watts	8750 Watts
Engine Size and Type	163cc OHV	206cc OHV	389cc OHV	389cc OHV	Generac 410cc OHVI	Generac 410cc OHVI
Pressure Lube w/Filter	No	No	No	No	Yes	Yes
Starting Method	Recoil	Recoil	Recoil	Recoil	Recoil	Electric/Recoil
Battery Included	N/A	N/A	N/A	N/A	N/A	Yes
Covered Outlets	No	No	No	No	No	No
Outlets	2x5-20R	4x5-20R	4x5-20R 1x14-30R	4x5-20R 1xL14-30R	4x5-20R 1xL14-30R	4x5-20R 1xL14-30R
Hour Meter w/ Maintenance Resets	No	No	Yes	Yes	Yes	Yes
Low-Oil Shutdown	Low Level	Low Level	Low Level	Low Level	Low Pressure	Low Pressure
Fuel Tank Type and Size	Steel, 4.0 Gal	Steel, 4.0 Gal	Steel, 6.6 Gal	Steel, 6.6 Gal	Steel, 8.0 Gal	Steel, 8.0 Gal
Run Time at 50%	14 Hours	13.5 Hours	9 Hours	9 Hours	11 Hours	11 Hours
Cord Set Included	No	No	Mp	No	No	No
Handles	Folding	Folding	Fold Down/Locking	Fold Down/Locking	Fold Down/Locking	Fold Down/Locking
First Oil Included	Yes	Yes	Yes	Yes	Yes	Yes
Maintenance Kit Included	No	No	No	No	No	No
Emission Certified			49 States	49 States ¹	49 States	49 States
CSA Certified Models	Available Jan 2008	Available Jan 2008	Available Dec 2008	Yes	Yes	N/A
Warranty	2 Year Limited	2 Year Limited	2 Year Limited	2 Year Limited	2 Year Limited	2 Year Limited
Dimensions (L" x W" x H")	23.5 x 17 x 17.5	25.5 x 21 x 19	33.5 x 26.5 x 27.5	33.5 x 26.5 x 27.5	33.5 x 26.5 x 27.5	33.5 x 26.5 x 27.5
Product Weight	90.5	101.5	185	185	190	195

¹ California models available October '08

Product Specifications

QT04542*	QT04842*	QT06024	QT06030	QT07068	QT08046	QT10068*	QT13068	QT15068
45 kW	48 kW	60 kW	60 kW	70 kW	80 kW	100 kW	130 kW	150 kW
42 kW	45 kW	60 kW	60 kW	68 kW	78 kW	97 kW	130 kW	150 kW
187.5	200	250	250	291.6	333.3	416.6	541.6	625
156.3	167	208.4	208.4	243.1	277.9	347.3	451.5	521
135.4	144	180.6	180.6	210.7	240.8	301	391.3	451.5
67.7	72	90.3	90.3	105.3	120.4	150.5	195.6	225.7
1800/1800	1800/1800	3600/3600	3600/3600	1800/1800	3600/3600	2300/1800	3000/1800	3600/3600
4.2L	4.2L	2.4L	3.0L	6.8L	4.6L	6.8L	6.8L	6.8L
V-6	V-6	In-line 4	V-6	V-10	V-8	V-10	V-10	V-10
240.1 (6.6)	261 (7.2)	332 (9.0)	381.3 (10.48)	411 (11.3)	465 (12.78)	507 (13.9)	719.8 (19.56)	830.6 (22.6)
630	661	862	960	1020	1154	1260	1786	2061
Yes	Yes	Yes	Yes	Yes	Yes	Yes	Yes	Yes
60	60	63	63	61	64	61	65	66
65	65	71	71	65	74	72	75	79
RTS	RTS	RTS	RTS	HTS	HTS	HTS	HTS	HTS
Aluminum	Aluminum	Steel or Alum	Steel or Alum	Steel or Alum	Steel or Alum	Steel or Alum	Steel or Alum	Steel or Alum
Gray	Gray	Tan	Tan	Tan	Tan	Tan	Tan	Tan
77 x 33.5 x 45	77 x 33.5 x 45	89 x 34 x 48	90 x 33.5 x 48**	96.5 x 37 x 48	116 x 37 x 55**	116 x 37 x 55**	116 x 37 x 55**	116 x 37 x 55**
N/A	N/A	1650	1650	2185	2010	2705/2755 ²	2873	2666
1703/1753 ²	1740/1790 ²	1650	1513	2040	1836	2531/2581 ²	2699	2492

GP8000	GP8000E	ULTRA SOURCE	ULTRA SOURCE	XP8000E
5680	5681	4582	4583	5606
8000 Watts	8000 Watts	15000 Watts	17500 Watts	8000 Watts
10000 Watts	10000 Watts	22500 Watts	26250 Watts	12000 Watts
Generac 410cc OHVI	Generac 410cc OHVI	Generac 992cc OHVI	Generac 992cc OHVI	Generac 410cc OHVI
Yes	Yes	Yes	Yes	Yes
Recoil	Electric/Recoil	Electric	Electric	Electric/Recoil
N/A	Yes	Yes	Yes	Yes
No	No	No	No	Yes
4x5-20R 1xL14-30R	4x5-20R 1xL14-30R	2x5-20R GFCI 2x5-20R 2xL5-30R 1xL14-30R 1x14-50R 1x10A 12Vdc	2x5-20R GFCI 2x5-20R 2xL5-30R 1xL14-30R 1x14-50R 1x10A 12Vdc	GFCI 4x5-20R 1xL14-30R
Yes	Yes	No	No	Yes
Low Pressure	Low Pressure	Low Pressure	Low Pressure	Low Pressure
Steel, 8.0 Gal	Steel, 8.0 Gal	Resin, 16.0 Gal	Resin, 16.0 Gal	Steel, 8.0 Gal
8 Hours	8 Hours	10 Hours	10 Hours	8 Hours
No	No	No	15' 50A ¹	25' 30A
Fold Down/Locking	Fold Down/Locking	Fixed, D-Style	Fixed, D-Style	Fold Down/Locking
Yes	Yes	Yes	Yes	Yes
No	No	Yes	Yes	Yes
49 States	49 States	50 States	50 States	49 States ¹
N/A	Yes	No	No	Yes
2 Year Limited	2 Year Limited	2 Year Limited	2 Year Limited	3 Year Limited
33.5 x 26.5 x 27.5	33.5 x 26.5 x 27.5	48.5 x 30.75 x 38.5	48.5 x 30.75 x 38.5	32.5 x 26 x 29
200	205	375	400	255

All portable specifications and models subject to change. Please consult factory for availability.

Product Selection Guide

QT SERIES GENERATORS

	STEP 1	STEP 2	STEP 3	STEP 4	STEP 5	STEP 6
	kW Ratings e.g. (45 kW = 045)	Engine e.g. (5.4L = 54)	Voltage 120/240 1Ø = A 120/208 3Ø = G 120/240 3Ø = J 277/480 3Ø = K	Fuel Natural Gas = N Propane Vapor = V Field Convertible to LP = *	Enclosure Steel = S Aluminum = A	Emission/Catalytic Converter No Catalyst = N ¹ Catalyst & A/F Ratio = Y
ALL MODELS BEGIN WITH QT	22	2.4L @ 1800 RPM	A, G	N*	A	N/A
	25	1.6L @ 3600 RPM	A, G	N*	S	N/A
	25	2.4L @ 1800 RPM	A, G	N*	A	N/A
	27	2.4L @ 1800 RPM	A, G	N*	A	N/A
	30	1.6L @ 3600 RPM	A, G	N*	S	N/A
	35	4.2L @ 1800 RPM	A, G, J, K	N*	A	N/A
	36	2.4L @ 1800 RPM	A, G, J, K	N*	A	N/A
	45	2.4L @ 3600 RPM	A, G, J, K	N*	S	N, Y
	45	4.2L @ 1800 RPM	A, G, J, K	N*	A	N, Y
	48	4.2L @ 1800 RPM	A, G, J, K	N*	A	N, Y
	60	2.4L @ 3600 RPM	A, G, J, K	N, V	S, A	N
	60	3.0L @ 3600 RPM	A, G, J, K	N, V	S, A	N
	70	6.8L @ 3600 RPM	A, G, J, K	N, V	S, A	N
	80	4.6L @ 3600 RPM	A, G, J, K	N, V	S, A	N
	100	6.8L @ 2300 RPM Gear Drive	A, G, J, K	N, V	S, A	N, Y
	130	6.8L @ 3000 RPM Gear Drive	A, G, J, K	N, V	S, A	N
150	6.8L @ 3600 RPM	A, G, J, K	N, V	S, A	N	
SAMPLE	Q T	0 6 0	2 4	K	N	S
	Q T					

MODEL NUMBER (Enter on Order Form)

1 = Catalyst & A/F Ratio may not be available for all models. Contact Your Generac representative for more information.

TRANSFER SWITCHES

	STEP 1	STEP 2	STEP 3	STEP 4	STEP 5
Selection Criteria	Transfer Switch R-100 Controller = RTS H-100 Controller = HTS	Switch Type Normal = N Service Entrance Rated ¹ = E 8 cct. Integrated Load Center ² = D 10 cct. Integrated Load Center ² = F 12 cct. Integrated Load Center ² = H 14 cct. Integrated Load Center ² = P 16 cct. Integrated Load Center ² = W 16 cct. Priority Load Center, Load Shedding ³ = S	Amp Rating e.g. (200 Amp = 200)	Voltage 120/240 1Ø = A 120/208 3Ø = G 120/240 3Ø = J 277/480 3Ø = K	Enclosure Type ^{4,5} NEMA 1 = 1 NEMA 3R = 3 NEMA 12 = 4
For Standby Generators 8 - 60 kW	RTS	N, E, D, F, H, P, W, S	100, 200, 400	A, G, J, K	1, 3
For Standby Generators 70 - 150 kW	HTS	N	100, 150, 200, 400, 600, 800	A, G, J, K	1, 3, 4
SAMPLE	R T S	N	2 0 0	G	3

PRODUCT NUMBER
(Enter on Order Form)

1 = 120/240 1Ø, NEMA 3R Only
2 = 100 amp, 120/240 1Ø, NEMA 1 Only

3 = 200 amp, 120/240 1Ø, NEMA 3R Only
4 = HTS 100 - 400 Amp NEMA 1/3R Only

5 = HTS 600 - 800 Amp NEMA 12/3R Only

A TRADITION OF QUALITY AND INNOVATION

For almost 50 years, Generac Power Systems has led the industry with innovative design and superior manufacturing. When it comes to developing products that are both durable and reliable, we stand head and shoulders above our competition. That's because our sole focus has been, and continues to be, standby power. The result of our efforts can be seen in every inch of our product offerings.

Our vertical integration allows us to control the quality, availability and flow of materials throughout the manufacturing process. We design and build our own air-cooled engines, alternators, control systems, automatic transfer switches, enclosures and base tanks (for diesel and Bi-Fuel™ models). Our products are fully integrated as complete power systems and each genset is factory tested prior to shipment.

Because of our ongoing commitment to quality and innovation, Generac is the name that home and business owners have come to trust.

COMMITMENT TO SERVICE

Generac is committed to providing our customers with unsurpassed after-the-sale service support. Our nationwide dealer network has factory trained technicians on staff and maintains large inventories of Generac parts, components and accessories.

Our state-of-the-art training center ensures that Generac service technicians are always up to date on new product innovations and improvements. Technicians receive comprehensive technical training and extensive hands-on experience in the installation, repair and maintenance of Generac products.

Generac's commitment to service includes scheduled maintenance programs, warranty assistance and emergency service to ensure that Generac customers are never left in the dark.



GENERAC[®]
POWER SYSTEMS, INC.



Acterra Group, Inc.☐
Corporate Centre 200☐
P.O. Box 160☐
Marion, IA 52302-0160☐
800.289.7371☐
www.acterragroup.com

Specifications are subject to change without notice.

Bulletin 0170030SBY / Printed in USA 04.04, rev. 08.08

